

ARTICULO: 2232A
Válvula de Compuerta con extremos bridados ANSI 150
Gate Valve with flanged ends ANSI 150

Características

1. Válvula de compuerta Clase 150.
2. Diseño según EN ISO 15761 (API 602).
3. Construcción en Acero Forjado ASTM A105.
4. Asiento inoxidable endurecido con Stellite.
5. Compuerta Inoxidable.
6. Trim # 8 (equivalente XU).
7. Extremos bridados según ANSI B 16.5.
8. Bonete atornillado.
9. Presión máxima de trabajo 19 bar.
10. Temperatura Máxima de trabajo: 420 °C.

Features

1. Gate valve 150 Class.
2. Design according to EN ISO 15761 (API 602).
3. Made by Forged Steel ASTM A105.
4. Stainless Steel Seat hardened with Stellite.
5. Stainless Steel Wedge Disc.
6. Trim # 8 (equivalent to XU).
7. Flanged ends according to ANSI B 16.5.
8. Bolted Bonnet.
9. Max. Working pressure 19 bar.
10. Max. Working temperature 420 °C.

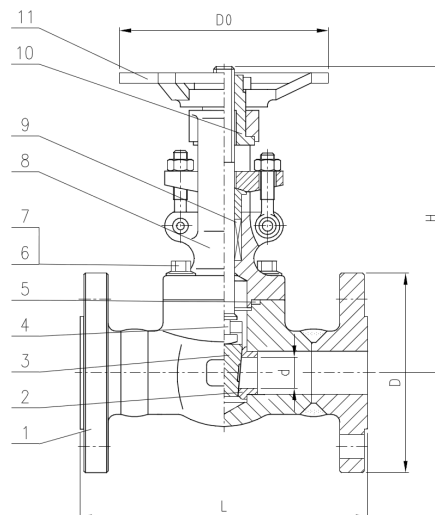

Nº	Denominación / Name	Material	Acabado Superficial / Surface Treatment
1	Cuerpo / Body	ASTM A105	Fosfatizado / Phosphatized
2	Asiento / Seat	ASTM A276-410 + STL.	-----
3	Compuerta / Wedge	ASTM A182 F6a	-----
4	Eje / Stem	ASTM A276 - 410	-----
5	Junta Cuerpo / Body Gasket	S.S 304 + Graphite	-----
6	Tornillo tapa / Bonnet Bolt	ASTM A193 Gr. B7	-----
7	Tuerca tapa / Bonnet Nut	ASTM A194 Gr. 2H	-----

Nº	Denominación / Name	Material	Acabado Superficial / Surface Treatment
8	Tapa / Bonnet	ASTM A105	Fosfatizado / Phosphatized
9	Estopada / Stem packing	Grafito / Graphite	-----
10	Tuerca Eje / Stem Nut	ASTM A276 - 410	-----
11	Volante / Handwheel	Fundición / Cast Iron	Fosfatizado / Phosphatized

DIMENSIONES GENERALES / GENERAL DIMENSIONS

Ref	Medida / Size	Dimensiones / Dimensions (mm)					Peso / Weight (Kg)
		d	L	H	D0	D	
2232A 04	1/2"	10.5	108	157	80	90	3,400
2232A 05	3/4"	13	117	163	80	100	3,800
2232A 06	1"	17	127	194	105	110	5,850
2232A 07	1 1/4"	22	140	196	140	115	7,300
2232A 08	1 1/2"	29	165	217	140	125	10,000
2232A 09	2"	36	178	251	160	150	15,200

DIAGRAMA DE PERDIDAS DE CARGA / HEAD LOSSES DIAGRAM

(H₂O – 20 °C Flujo Horizontal / Horizontal flow).

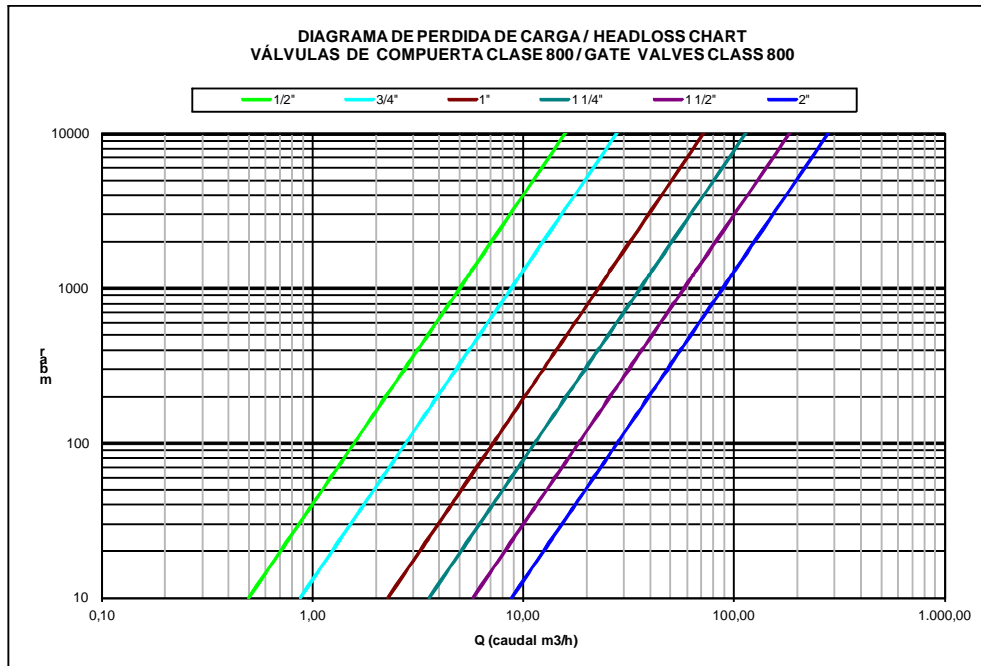

VALORES DE Kv / Kv VALUES

Kv = Es la cantidad de metros cúbicos por hora que pasará a través de la válvula generando una pérdida de carga de 1 bar.

Kv = The rate of flow of water in cubic meter per hour that will generate a pressure drop of 1 bar across the valve.

Med. / Size	1/2"	3/4"	1"	1 ¼"	1 ½"	2"
m ³ /h	5	8.8	22.8	36.1	57.9	88.2

CURVA PRESION TEMPERATURA / PRESSURE TEMPERATURE RATING

